

KHA-2 mit Schweißstutzen, Hahngriff und freier Welle
 KHA-2 with welding end pieces, hand lever and free stem

Model: WOH34263_S
 Drawing: WOH34263_S

Urheberschutz nach
 Copyright acc. to
 Droit d'auteur selon
 ISO 16016

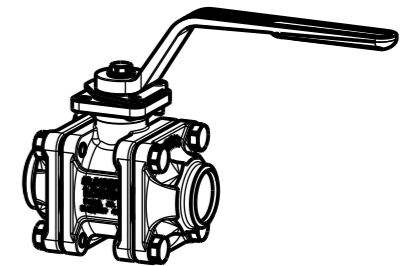
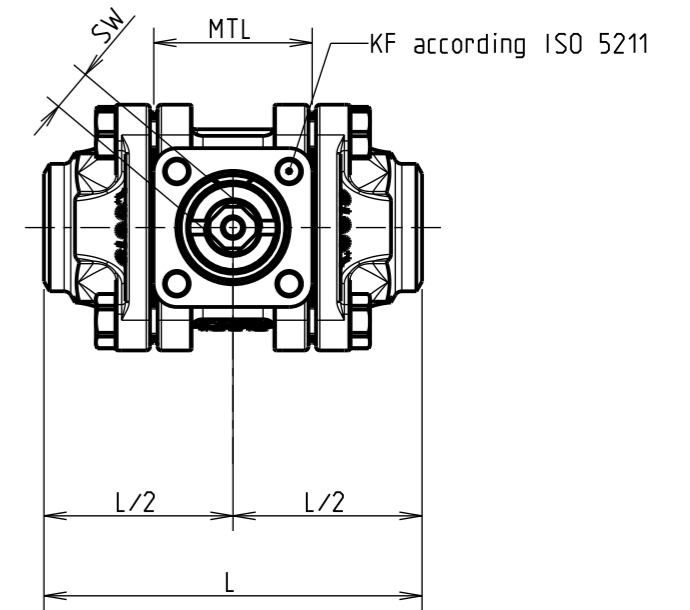
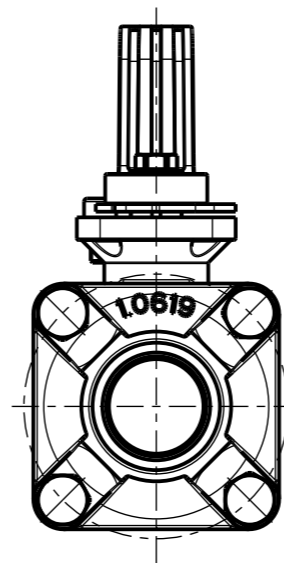
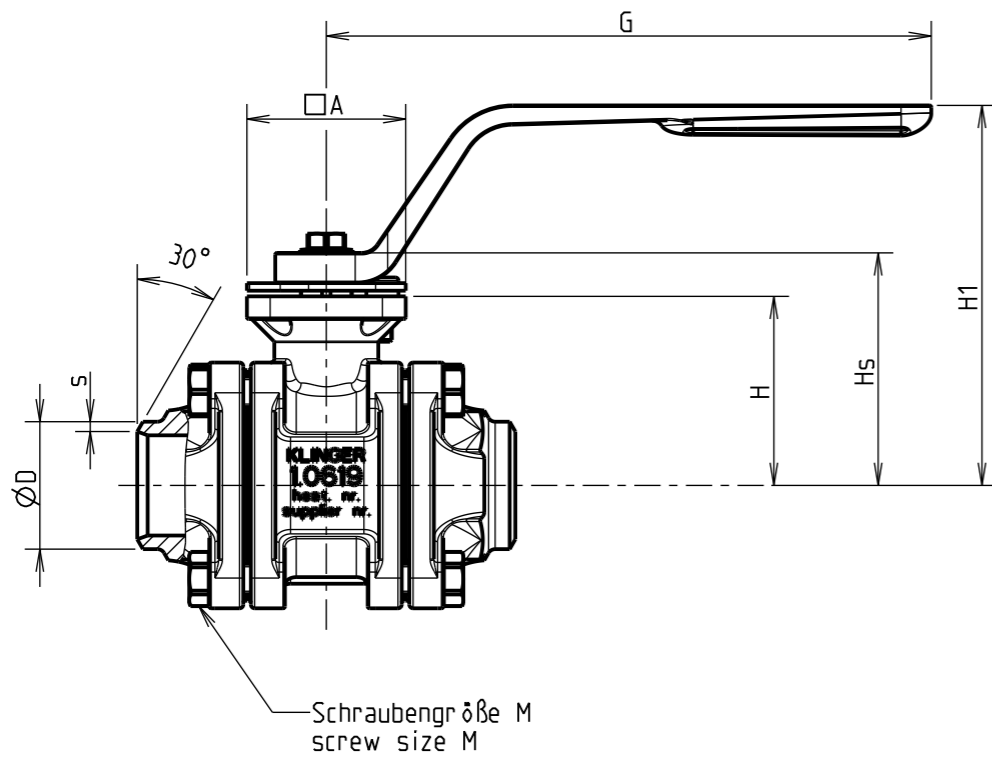

DN	MTL	KF	□A	SW	M	n*M	H	Hs	H1	L (EN)	ØD	s	G	mass [kg] *)	
15	26.4	F04	42	8	M6	4	35	43.5	83	75	21.3	2.0	130	0.85	
20	35.2			11	M8		46.5	57	96	90	28.0	3.0		160	1.45
25	41.5			14	M10		50	60.5	100	100	33.7	2.6			1.80
32	49.5	F05	50	14	M12		65	77.7	107.5	110	42.4	2.6	252	3.10	
40	63				M14		72.5	85.2	114.7	125	48.3	3.2		4.75	
50	77.5	F07	70	17	M12		90	106.2	136.2	150	60.3	2.9	310	7.60	
65	93.5				M16	100	116.2	146.2	190	76.1	3.1	10.60			
80	111.4	F10	102	22	M16	6	121.5	143	165	220	88.9	3.2	500	19.50	
100	131.6						135	156.5	178.5	270	114.3	3.6		28.00	
125	171.4						F12	125	27	8	175	202.5		212.5	330

*) Masse entspricht einem in CAD errechneten Wert
 Mass corresponds to a value calculated in CAD